

VTA04, TA04



- Excellent frequency stability across a wide temperature range.
- Good Reliability, Low cost.
- Low frequency range.
- High quality TCXO for communication equipment.

Table1 Specifications

Parameter		VTA04, Ta04
Frequency Range		500KHz~8MHz
Initial Calibration Tolerance(@25°C ±2°C)		Models with internal trimmer :Adjust to the nominal frequency Models without internal trimmer : ± 1ppm typical
Frequency Stability	vs Operation Temp.Range	See Table 2
	vs Vcc Change ± 5%	± 0.3ppm
	vs Load Change ± 10%	± 0.3ppm
	vs Aging	± 1ppm
Operation Temperature Range		See Table 2
Supply Voltage		3.3V,5.0V,8.0V
Current Consumption		20mA max
Output		TTL/CMOS, Code is "T"
Start-up Time		2ms max
SSB Phase Noise		-135dBc@1KHz,5MHz,typical
Frequency Tuning Range (@25°C ±2°C)		±3ppm typical, by internal trimmer
VCTCXO only	Frequency Tuning Range	±5~ ±30ppm, ±10ppm typical
	Control Voltage Range	1.65V ± 1.5V@3.3Vcc, 2.5V ± 2V@5.0Vcc
	Slope Polarity	Positive
	Linearity	10%max
Package		A11,A12,A13,A14,A15,A16
Storage Temperature Range		-55~+85°C

Table2 Frequency Stability vs Operation Temperature Range(Ref to 25°C) and Option Code

	±1.0ppm	±1.5ppm	±2.0ppm	±2.5ppm	±3.0ppm	±5.0ppm
0~50°C	A10	A15	A20	A25	A30	A50
-10~60°C	B10	B15	B20	B25	B30	B50
-20~70°C	C10	C15	C20	C25	C30	C50
-30~75°C		D15	D20	D25	D30	D50
-40~85°C					E30	E50

TCXOs

Part Numbering Key

Sample Part Numbers
VTA04-5TD20-A11
 @20.000MHz

SERIES	SUPPLY VOLTAGE	OUTPUT FORM	FREQ.STABILITY vs.TEMP	PACKAGE CODE	FREQUENCY
TA04	3.3=3.3V	T=TTL/CMOS	See Table2	A11,A12,	
VTA04	5=5.0V 8=8.0V			A13,A14 A15,A16	
VTA04	5	T	D20	A11	20.000MHz

Package A11,12,13 Unit:mm

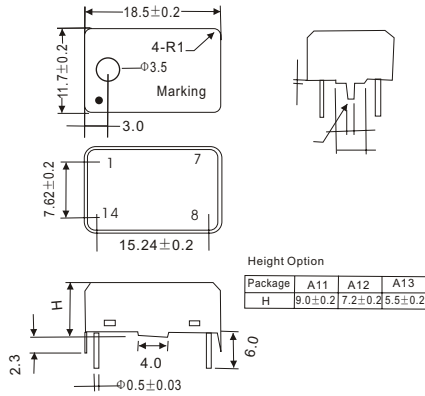

Pin Connections
 Pin 1: Voltage Control for VCTCXO; No Connection for tcxo
 Pin 7: Ground
 Pin 8: Output
 Pin 14: Supply Voltage

Package A14 Unit:mm

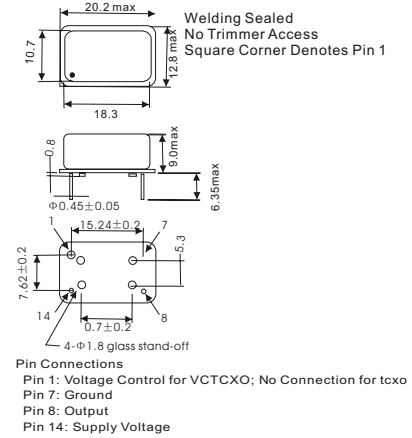

Test Circuit for CMOS Output

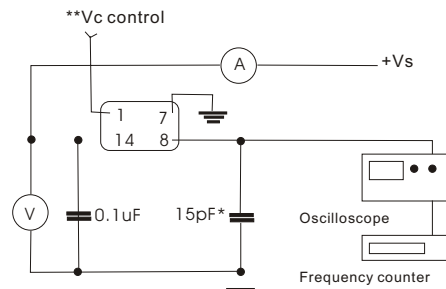

*Inclusive of jigging & equipment capacitance
 **Pin 1 has non connection for Non VFC

Package A15 Unit:mm

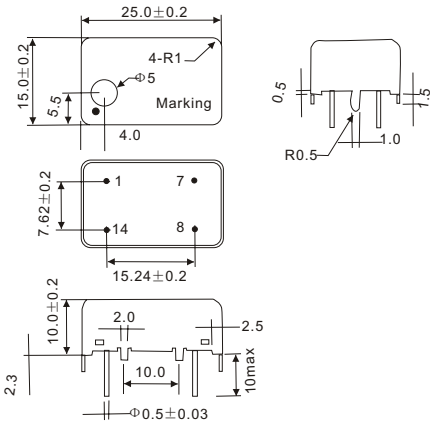

Pin Connections
 Pin 1: Voltage Control for VCTCXO; No Connection for tcxo
 Pin 7: Ground
 Pin 8: Output
 Pin 14: Supply Voltage

Test Circuit for Clipped Sine & Sine Output

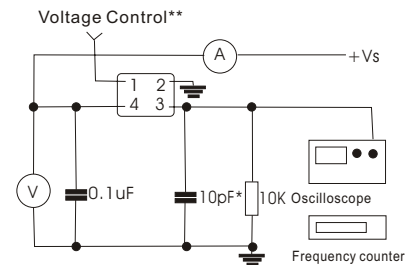

*Inclusive of jigging & equipment capacitance
 **Pin 1 has non connection for Non VFC

Package A16 Unit:mm

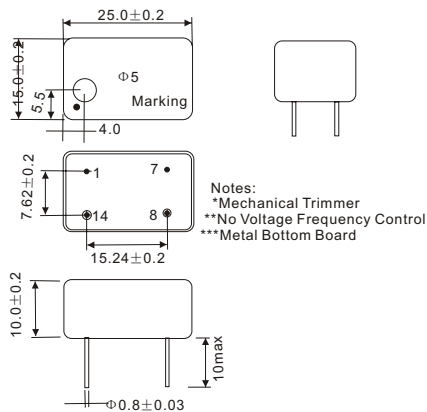

Pin Connections
 Pin 1: Ground
 Pin 7: Ground
 Pin 8: Output
 Pin 14: Supply Voltage

Test Circuit for TTL Output

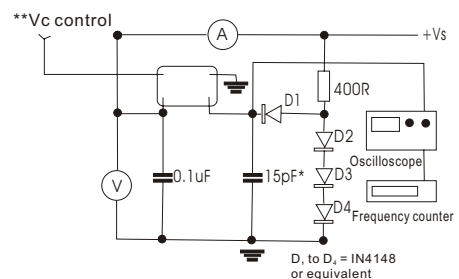

*Inclusive of jigging & equipment capacitance

Marking TA,VTA

1. Frequency
2. Part Number
3. S/N if needed
4. Year & Month
5. Company Name